

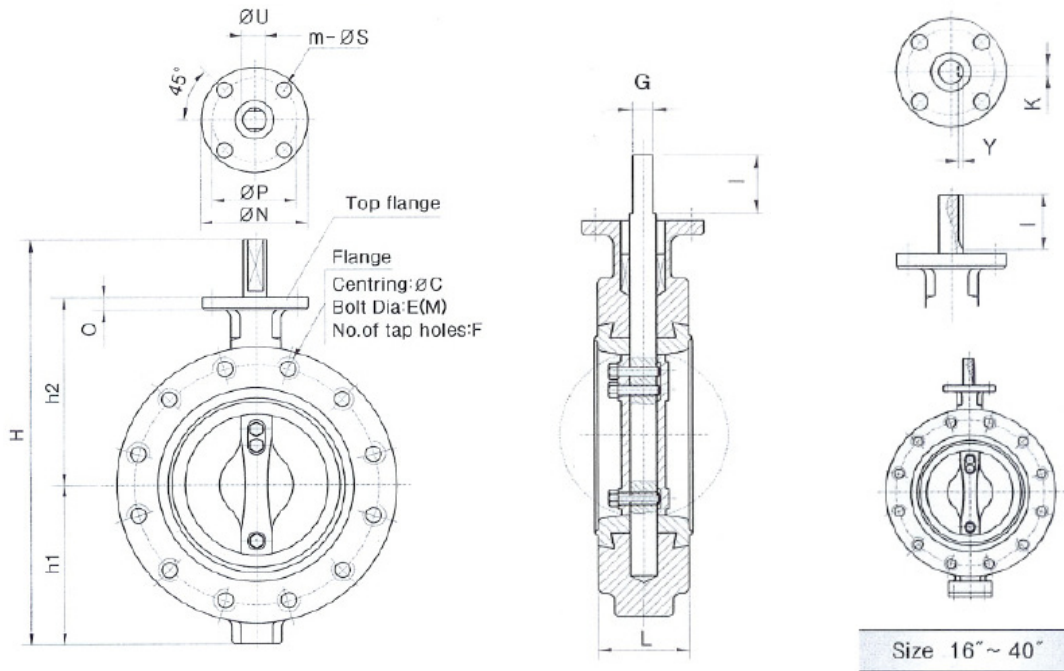

# BUTTERFLY VALVE - DOUBLE FLANGE BODY



## VALVE DIMENSIONS

Size		L	H	h1	h2	Stem		Top flange to ISO 5211					O	WT (kg)
Inch	mm					ØU	G	Type	ØN	ØP	m	ØS		
1½"	40	41	205	58	124	10	8	F07	90	70	4	9	10	6.2
2"	50	43	240	77.5	130.5	14	10	F07	90	70	4	9	11	6.8
2½"	65	46	247	87.5	129.5	14	10	F07	90	70	4	9	11	8.9
3"	80	46	266	92.5	143	14	10	F07	90	70	4	9	11	10.2
4"	100	52	298	105	160.5	16	12	F07	90	70	4	9	11	14.5
5"	125	56	331	125	177	19	15	F07	90	70	4	9	12	16.8
6"	150	56	363	140	191	19	15	F07	90	70	4	9	12	19.8
8"	200	60	412	163	217	22	18	F07	90	70	4	9	13	31.2
10"	250	68	506	205	267	28	20	F10	125	102	4	12	15	46.2
12"	300	78	538	248.5	295	28	20	F10	125	102	4	12	15	58.8

## FLANGE DRILLING

Size		L	H	h1	h2	Stem					Top flange to ISO 5211					O	WT (kg)
Inch	mm					ØU	G	I	Y	K	Type	ØN	ØP	m	ØS		
14"	350	78	675	271	324	32	19.5	45	-	-	F10	125	102	4	12	20	66.6
16"	400	102	817	343	369	35	-	60	5	10	F14	175	140	4	18	23	96
18"	450	114	877	366	406	38	-	60	5	10	F14	175	140	4	18	23	147
20"	500	127	1008	421	485	45	-	60	5	10	F16	210	165	4	22	34	161
22"	550	140	1050	450	530	45	-	60	5	10	F16	210	165	4	22	34	268
24"	600	154	1180	493	570	50	-	60	5	10	F16	210	165	4	22	34	292
26"	650	165	1260	540	570	50	-	120	5	10	F16	210	165	4	22	34	410
28"	700	165	1355	580	574	70	-	120	5	10	F25	300	254	8	18	35	539
30"	750	180	1445	656	615	70	-	120	5	10	F25	300	254	8	18	35	658
32"	800	180	1495	630	669	80	-	140	5.5	14	F25	300	254	8	18	35	745
36"	900	180	1625	690	671	80	-	140	5.5	14	F30	350	298	8	22	38	944
38"	950	200	1650	710	800	90	-	140	5.5	14	F30	350	298	8	22	38	1260
40"	1000	200	1802	790	842	90	-	140	5.5	14	F30	350	298	8	22	40	1307
48"	1200	276	2130	910	1070	120	-	150	7	22	F30	415	356	8	33	40	1990